



WILDERNESS™
Accessories
MFG. BY GARVIN INDUSTRIES

**Manufacturers of Specialty Products
for Sport Utility and 4x4 Vehicles**

316 Millar Avenue • El Cajon, CA 92020
Phone 619/440-7415 • FAX 619/440-0851

Wilderness Jeep Front Bumper

76-86 CJ7

Part# 34919(54")

Part# 34918(44")

Mounting Hardware Kit

4-7/16" x 1 1/4" Bolts

8-7/16" USS Flatwashers

4-7/16" Lockwashers

4-7/16" Nuts

Installation Instructions

1. Remove factory front bumper from vehicle.
2. Install Wilderness front bumper to frame as shown
3. Start all four mounting bolts and leave loose.
4. Align bumper to vehicle and tighten the two top bolts first, then tighten the lower bolts and the lower mount tabs will slightly bend to conform to the frame.
5. **Note!** The two brackets welded to the top of the clevis pin mounts are designed to mount the pre-runner guard(Part#34924). Also, they give extra strength on side pulls when the clevis mounts are used for vehicle retrieval.
6. **Vehicle Retrieval:** **A.** The front clevis pin mounts are designed to be used for vehicle retrieval. The mountings are secured through the bumper and welded on both sides along with the welded top side braces. **B.** The Warn(Part#29312) or Superwinch(Part#2546) receiver shackle bracket with clevis pin can be inserted into the front bumper receiver hitch for vehicle retrieval.

Front Bumper Accessories

- ◆ Pre-Runner Guard(Part#34924)
- ◆ Light Mounting Brackets(Part#34926)
- ◆ Front License Plate Bracket(Part#34925)

WILDERNESS 76-86 CJ JEEP® FRONT BUMPER
 General Assembly Drawing

Part No. 34919 54"

Part No. 34918 44"



WILDERNESS™
Accessories
 MFG. BY GARVIN INDUSTRIES

PAGE 1 OF 1

JEEP FRAME RAIL

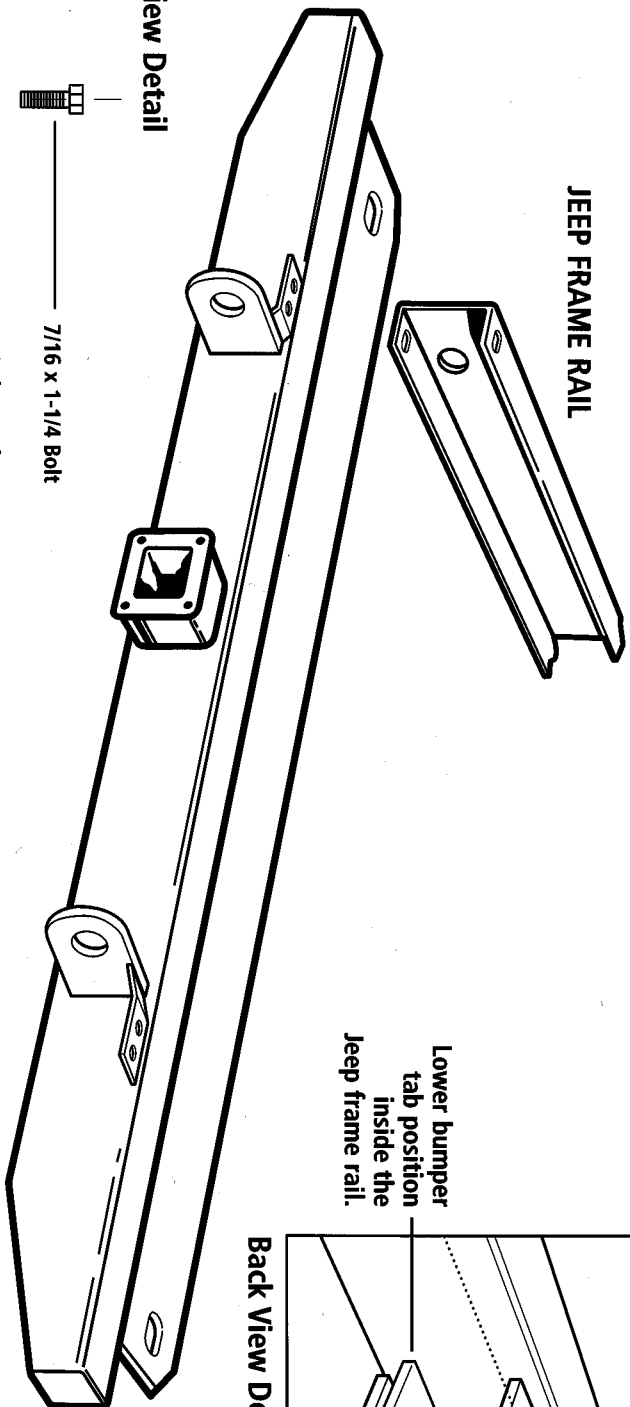

Lower bumper
 tab position
 inside the
 Jeep frame rail.

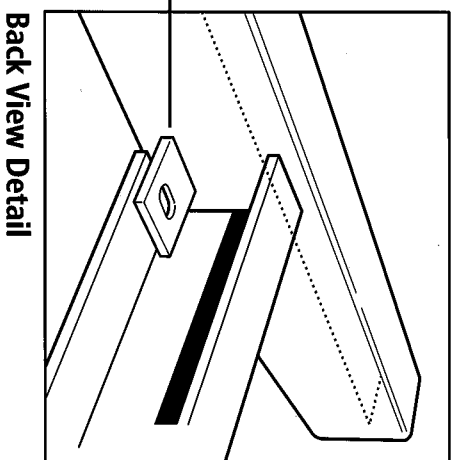

Back View Detail

Side View Detail

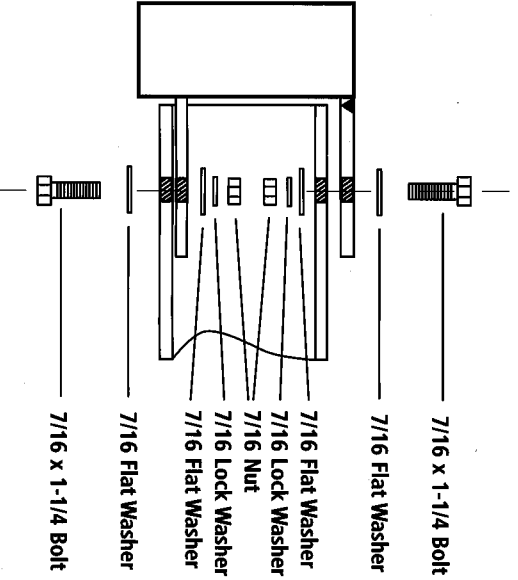

HARDWARE LIST	
4 - 7/16" x 1-1/4" bolts	
8 - 7/16" USS Flat washers	
4 - 7/16" Lock washers	
4 - 7/16" Nuts	